



example train wash:  
 free weathering  
 extreme influence of media (detergents)  
**travel 180 m**

The SYSTEM MARATHON is designed for long travel distances with a rolling-led energy chain.

The upper part of the chain runs with roller sets on a continuous flat guiding rail surface. This construction avoids completely the sliding friction between the upper and lower strand of conventional energy chains. In this movement only substantially lower rolling friction occurs.

In front of the chain radius the roller sets are lifted out of the guide rail. In the chain radius the roller sets are pivoted into the trough by means of polygonal shape and the chain is lowered in the trough.

In the opposite direction of travel the roller sets behind the chain radius swirl again, embrace the guide rail and carry the upper strand centered within the trough.

Measurements for the SYSTEM MARATHON confirmed that the reduction of friction forces is up to 90%. Increased starting torque, as with sliding applications and the overcoming of static friction after a stop will not appear with this system. Not least of all SYSTEM MARATHON minimizes wear through the rolling friction.

Another advantage is the parallel to the chain running force of the movable driver and the straight arrangement of the upper run which totally avoids changing bending of the lines and the energy chain. A substantially increased durability and reliability are the result.



example greenhouse:  
 relative humidity 80-100%  
**travel 150 m**

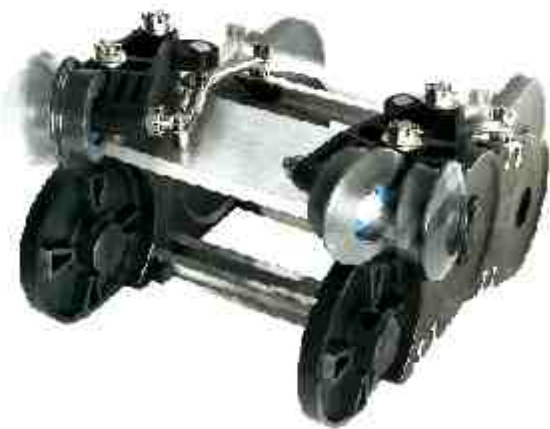



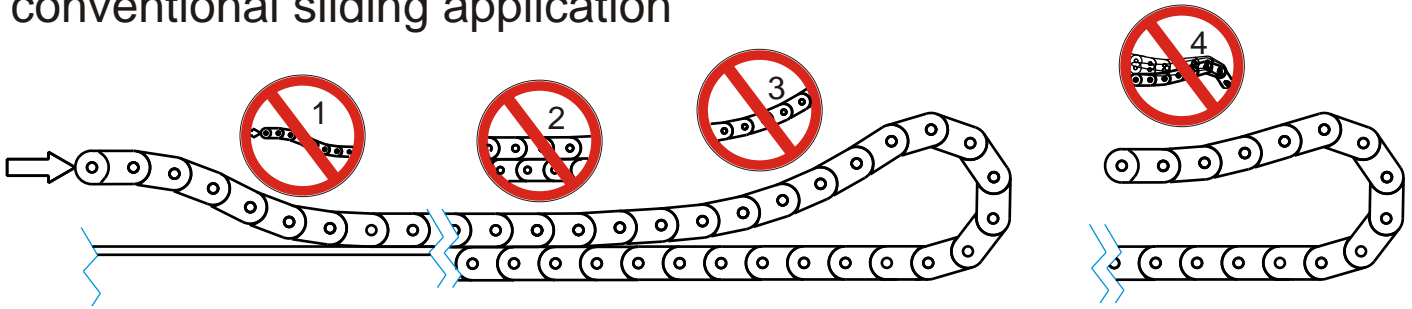

## conventional sliding application

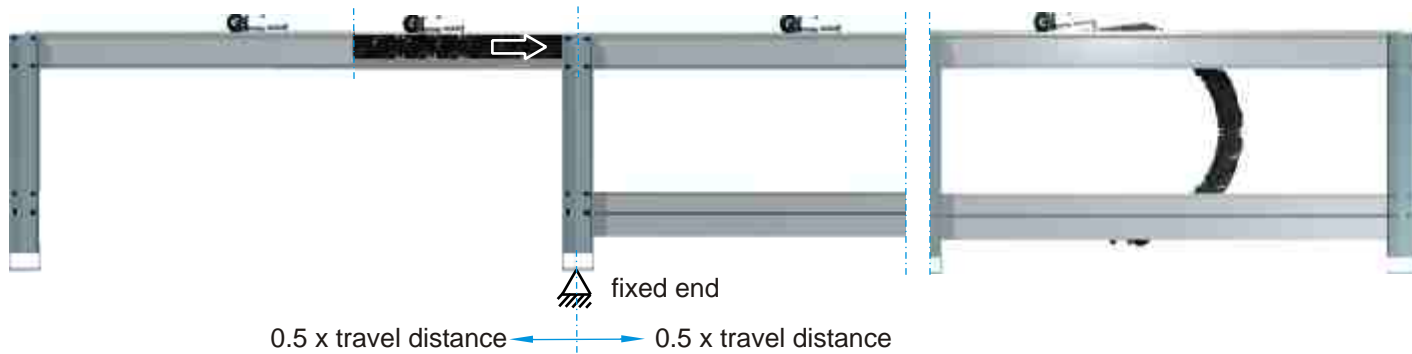

## SYSTEM MARATHON



-  of force not in energy chain direction  
high-flexing of the energy chain  
repeated bending of the lines
-  sliding friction: high forces  
high starting torque  
abrasion, wear, noise
-  bending of the energy chain and  
the lines
-  oscillations lead to extreme  
loads of the energy chain
- additional lengths often necessary

## SYSTEM MARATHON

moving forces reduced  
by up to 90%  
forces into the direction of  
Energy chain  
no repeated bending  
no increased starting torques  
abrasion and wear-minimizing

